

Caimi
BREVETTI



SOCRATE

Caimi
BREVETTI
1/18



SOCRATE: detail of the transparent glass shelf



SOCRATE: detail of the steel shelf



SOCRATE: detail of the steel sliding closing

The aesthetic virtues of the SOCRATE system

- A clean, streamlined design and understated elegance lend the Socrate system the unique ability to fit beautifully into any type of setting - in historic residences or modern new constructions. The sleek steel uprights afford a visually lightweight and extremely elegant appearance to the bookshelves. An example of perfect integration between form and function is achieved by the design of the horizontal and inclined steel rods that represent the stylistic character of the product as well as allow the shelves to be combined, without the use of additional supports.

- The Socrate system is an “open system” since it can evolve and transform, expand or change after its original arrangement as needed to fit the space. Rooms be decorated starting with its simple structure - adding the most appropriate accessories, changing up the finishes or details, to keep the look fresh and new. The spaces can be renovated as needed without having to change the basic elements.

- Using the Socrate system, it is possible to create complete furnishings, from bookshelves and display cases to retail furnishings, etc., while maintaining a certain stylistic uniformity.

- The systems are completed by a large number of accessories that can often be added as needed to either Socrate and Socrate Parete. Both Socrate lines share the same look and the same finishes, so they can be used together in the same room, without creating mismatched style. Another effective decorating idea is to pair Socrate with other furnishings in the room.

- The upright of the Socrate line is also available in chrome plated steel version to add even more elegance to the most sophisticated spaces or executive offices or reception areas.

Functional features

- The standardization of the product is expressed through the ability to combine several units, the ease of assembly and disassembly, and the interchangeability of the components, all features typical of industrial-produced products and designed and developed exactly for this purpose.

- Stability and durability are guaranteed by the skilful method of workmanship of the metal. The technical details have been studied to meet the safety requirements set down by current law - rounded edges, accident-proof end caps, folded metal sheet, superior hygiene and resistance to flame, etc.

- The product has been submitted to a number of stringent quality tests (UNI/EN)

- The shelves can be moved just about anywhere along the upright, thereby creating shelf space of variable heights, without wasting space.

- Several types of shelves are available, including shelves in scratch-proof micro-perforated steel sheet. The unusual micro-perforated texture and the powder-coated finish ensure exceptional durability against abrasion caused by sliding out books and moving racks.

- Durable powder-coated finish in mat white and metal grey for the uprights and metal grey and matt white for the shelves and accessories. Note the special scratch-proof characteristic of the finish.

Technical information of the Socrate system

SHELVES:

96 cm shelf accommodates about 35 books

56 cm shelf accommodates about 20 books

96 cm shelf accommodates about 11 racks (8.5 cm wide)

56 cm shelf accommodates about 6 racks (8.5 cm wide)



SOCRATE



SOCRATE: detail of micro-perforated steel shelves



SOCRATE

Accessories

Socrate comes complete with a variety of accessories and can be easily incorporated with the SOCRATE PARETE system, also by Caimi Brevetti.



SOCRATE: detail of the steel hanger support

- The wide range of accessories produced by Caimi Brevetti can easily supply complete systems for any type of settings. The general product catalogue includes accessory articles such as waste paper baskets, floor-standing and wall-mounted coat racks, umbrella stands, display cases, computer stands, tables, chairs in individual and multiple seating configurations, office accessories, wall clocks, table lamps, etc

- Ease of functional transformation and application of accessory elements



SOCRATE: detail of the magazine rack

- The SOCRATE “Open” system is like a “mechanical game” that can subsequently evolve, expand or change the spaces created. One of the most interesting features of the product is its ability to increase the furnishings as needed and simply and practically change the layout of a room.

- The same system makes it possible to create bookshelves as well as any number of other decorating accessories, such as displays for new literary items and promotions, elements that can meet current needs of “on-line” consultation of computerized files or over the Internet, all the while maintaining a certain stylistic uniformity to the room.



SOCRATE: detail of the transparent feet

The SOCRATE system is frequently supplied for library furnishing uses because of its functional characteristics and because of its ability to expand in direct proportion to the expansion or changes in the library holdings.

Dimensions of the SOCRATE system

Depths: available in two sizes of 35 and 45 cm

Heights of the uprights for D45 cm: 238 - 200 - 162 - 105 - 86 - 47 cm

Heights of the uprights for D35 cm: 238 - 200 - 162 - 86 cm

Length: First unit L=100 or 60 cm
Following units L=96.5 and 56.5 cm

Upright colour: Mat white, metal grey or chrome-plated

Steel sheet shelf colour: Metal grey or matt white

Glass shelf colour: Transparent

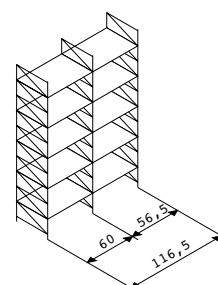
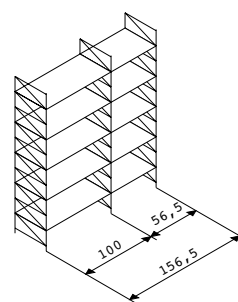
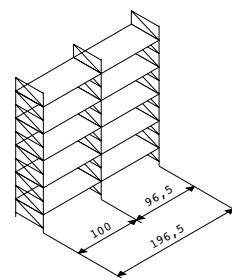
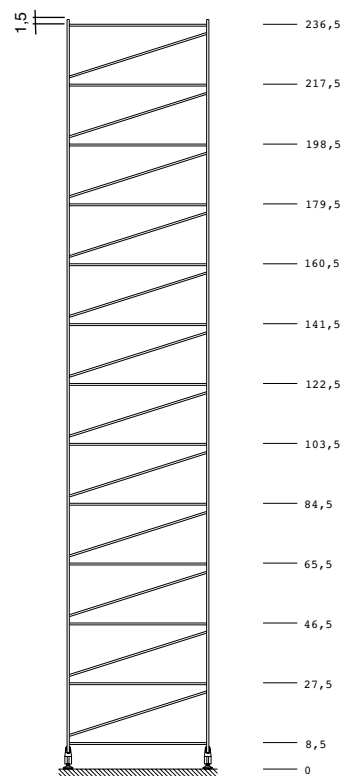
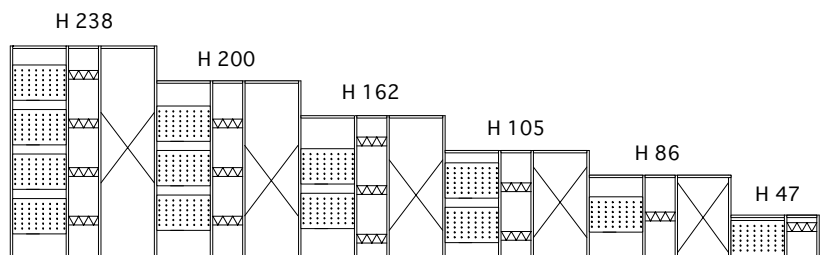

Load-bearing structures

Note that the elements necessary to ensure the stability of the Socrate units are: at least two uprights, at least two shelves and one or more load-bearing structures.

The minimum number of load-bearing elements to use for the various heights of the uprights are shown in table 1.

Remember that only the elements described in this paragraph are considered load-bearing elements, namely: bracing crosses, backs in steel rods or back panels in steel sheet.

Load-bearing elements are the articles listed in table 1

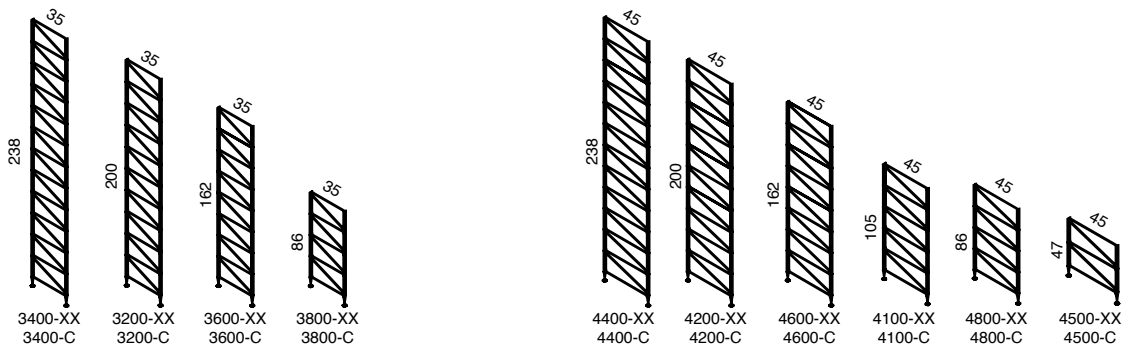

Uprights

Materials: welded, powder-coated steel rods

Colours: matt white or metal grey or chrome-plated steel

Features: uprights consist of three Ø7 mm steel rods line up at the front and three identical rods in the back, held together by pairs of diagonal rods Ø6 mm set 19 cm apart. The uprights have feet and tips in a high-tech polymer with threaded insert in zinc plated steel, high-tech polymer protective caps.

Notes: the distance between the vertical rods is 5 mm and allows M4 screws to pass through to fasten accessories, bracing crosses, etc

TABLE 1

	2910 2960		2712 2715		2722 2725		2716 2719	
	MIN.	MAX.	MIN.	MAX.	MIN.	MAX.	MIN.	MAX.
H 238	1	3	3	6	4	12	2	4
H 200	1	2	2	5	3	10	2	4
H 162	1	2	2	4	3	8	2	3
H 105	1	1	2	2	2	5	1	2
H 86	1	1	1	2	1	4	1	1
H 47	-	-	1	1	1	2	-	-

Minimum and maximum number of load bearing elements for a complete module.

4986/2

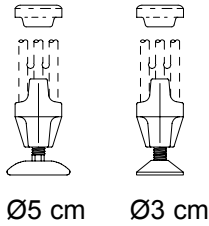

Feet and end caps for uprights:

Dimensions: Ø5 cm
Ø3 cm

Materials: - end caps in high-tech polymer
 - threaded insert and M10 zinc plated steel screws
 - support foot in high-tech polymer
 - upper protection caps in grey high-tech polymer

Colours: grey

4986/2-N



Feet and end caps for uprights:

Dimensions: Ø3 cm

Materials: - end caps in high-tech polymer
 - threaded insert and M10 zinc plated steel screws
 - support foot in high-tech polymer
 - upper protection caps in black high-tech polymer

Colours black

4986/2-T



Feet and end caps for uprights:

Dimensions: Ø3 cm

Materials: - end caps in translucent high-tech polymer
 - threaded insert and M10 zinc plated steel screws
 - load bearing foot in chrome-plated metal sheathed high-tech polymer
 - upper protection caps in translucent high-tech polymer

Colours: transparent

2910-XX
2960-XX

See table 1

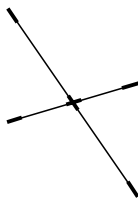

Bracing crosses:

Dimensions: L96 cm x Ø8 mm (cod.2910-XX)
 L56 cm x Ø8 mm (cod.2960-XX)

Materials: 2 flattened Ø8 mm steel rods with a hole at each end and at the centre.

Powder-coated or chrome-plated finish

Colours: matt white, metal grey or chrome-plated finish

Assembly: fasten together and to the uprights with M4 screws, wing nuts and washers

Notes: see table 1

2722-XX
2725-XX

See table 1

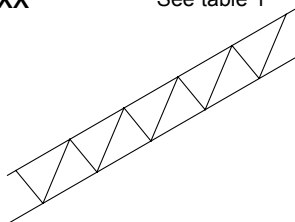

Backs:

Dimensions: L96 x H15 cm (cod.2722-XX)
 L56 x H15 cm (cod.2725-XX)

Materials: 2 flattened Ø8 mm steel rods with a hole at each end, welded together with a third shaped rod, powder-coated or chrome-plated finish

Colours: matt white, metal grey or chrome-plated

Assembly: fasten onto the upright with M4 screws, wing nuts and washers

Notes: see table 1

XX=colour option:
GM = Metal Grey
BO = Matt White
C = Chrome-plated

2712-XX
2715-XX

See table. 1

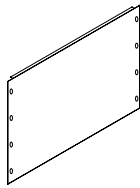

XX=colour option:
GM = Metal Grey
BO = Matt White

Steel sheet back panel:

Dimensions: L96 x H38 cm (cod.2712-XX)
L56 x H38 cm (cod.2715-XX)

Materials: 1 mm powder-coated steel sheet, folded upper, lower and side edges

Colours: metal grey or matt white

Assembly: fasten onto the upright with M4 screws, wing nuts and washers

Notes: see table 1

3910-XX 4910-XX
3960-XX 4960-XX

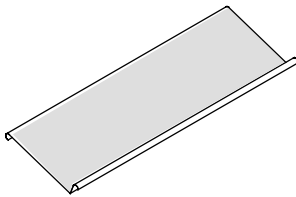

XX=colour option:
GM = Metal Grey
BO = Matt White

Inclined display shelves:

Dimensions: SOCRATE 35 L96 x D31,5 cm (cod.3910-XX)
L56 x D31,5 cm (cod.3960-XX)
SOCRATE 45 L96 x D41,5 cm (cod.4910-XX)
L56 x D41,5 cm (cod.4960-XX)

Materials: powder-coated micro-perforated steel sheet, folded for added stiffness on the front and rear edges, with rounded edges, 22 mm thick and folded front edge, H 4 cm

Colours: metal grey or matt white

Assembly: fitted onto the rods of the upright

3010-XX 4010-XX
3060-XX 4060-XX

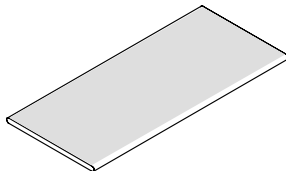

XX=colour option:
GM = Metal Grey
BO = Matt White

Micro-perforated steel sheet shelves:

Dimensions: SOCRATE 35 L96 x D33,5 cm (cod.3010-XX)
L56 x D33,5 cm (cod.3060-XX)
SOCRATE 45 L96 x D43,5 cm (cod.4010-XX)
L56 x D43,5 cm (cod.4060-XX)

Materials: powder-coated micro-perforated steel sheet, with folded edge for added stiffness on the front and rear edges, rounded 22,5 mm edges

Colours: metal grey or matt white

Assembly: fasten directly onto the horizontal rods of the uprights

3012-XX 4012-XX
3062-XX 4062-XX

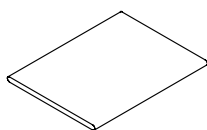

XX=colour option:
GM = Metal Grey
BO = Matt White

Steel sheet shelves:

Dimensions: SOCRATE 35 L96 x D33,5 cm (cod.3012-XX)
L56 x D33,5 cm (cod.3062-XX)
SOCRATE 45 L96 x D43,5 cm (cod.4012-XX)
L56 x D43,5 cm (cod.4062-XX)

Materials: powder-coated steel sheet, with folded edge for added stiffness on the front and rear edges, rounded 22,5 mm edges

Colours: metal grey or matt white

Assembly: directly onto the horizontal rods of the uprights

63010-XX 64R100-XX
63060-XX 64R600-XX

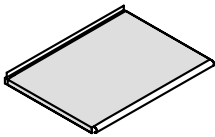

XX=colour option:
GM = Metal Grey
BO = Matt White

Micro-perforated steel sheet shelves with raised back edge:

Dimensions: SOCRATE 35 L96 x D33,5 cm (cod.63010-XX)
L56 x D33,5 cm (cod.63060-XX)
SOCRATE 45 L96 x D43,5 cm (cod.64R100-XX)
L56 x D43,5 cm (cod.64R600-XX)

Materials: powder-coated micro-perforated steel sheet, rounded 22,5 mm edges with frontal folded edge for added stiffness. The back edge is raised to hold the books and has a bottom rail to accommodate the sliding bookends

Colours: metal grey or matt white

Assembly: fasten directly onto the horizontal or inclined rods of the uprights

Notes: the shelves can be assembled straight or inclined

63012-XX 64R102-XX
63062-XX 64R602-XX

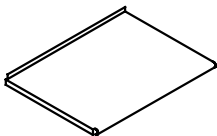

XX=colour option:
GM = Metal Grey
BO = Matt White

Steel sheet shelves with raised back edge:

Dimensions: SOCRATE 35 L96 x D33,5 cm (cod.63012-XX)
L56 x D33,5 cm (cod.63062-XX)
SOCRATE 45 L96 x D43,5 cm (cod.64R102-XX)
L56 x D43,5 cm (cod.64R602-XX)

Materials: powder-coated steel sheet, rounded 22,5 mm edges with frontal folded edge for added stiffness. The back edge is raised to hold the books and has a bottom rail to accommodate the sliding bookends

Colours: metal grey or matt white

Assembly: fasten directly onto the horizontal or inclined rods of the uprights

Notes: the shelves can be assembled straight or inclined

3973-GM
3974-GM

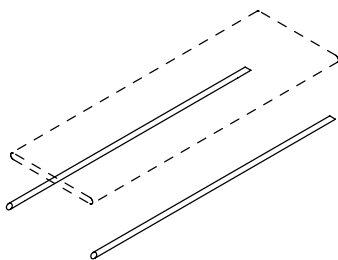

Reinforcement for metal TOP shelves positioned at a height of 100 cm or lower:

Dimensions: L 96 cm (cod.3973-GM)
L 56 cm (cod.3974-GM)

Materials: powder-coated steel tubular and end caps, threaded zinc-plated bars

Colours: metal grey

Assembly: under, at the rounded edge of the top shelves in steel

3014-XX 4014-XX
3064-XX 4064-XX

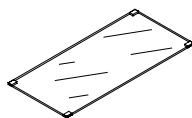

XX=colour option:
N = Black
GR = Grey
BO = White

Transparent glass shelves:

Dimensions: SOCRATE 35 L96 x D33,5 cm (cod.3014-XX)
L56 x D33,5 cm (cod.3064-XX)
SOCRATE 45 L96 x D43,5 cm (cod.4014-XX)
L56 x D43,5 cm (cod.4064-XX)

Materials: - shelf in tempered float glass, 8 mm thick
- shelf brackets in black, grey or white high-tech polymer

Assembly: fasten directly onto the horizontal rods of the uprights with high-tech polymer shelf supports

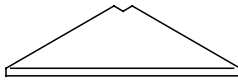
4000-XX

XX=colour option:
GM = Metal Grey
BO = Matt White

Steel corner shelf:

Dimensions: SOCRATE 45 L43,5 x D43,5 cm (cod.4000-XX)

Materials: 1 mm powder-coated steel sheet, rounded front edge,
22 mm thick

Colours metal grey or matt white

Assembly: fit into the horizontal rods of the upright

2678-XXXX

See table 2

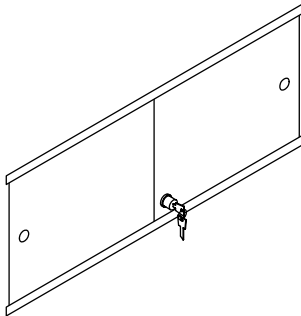
**XXXX=colour option:**

GMGM = Metal Grey closings, Metal Grey slides
GMBO = Metal Grey closings, Matt White slides
BOGM = Matt White closings, Metal Grey slides
BOBO = Matt White closings, Matt White slides

Steel sheet sliding closings with lock:

Dimensions: L96 x H36 cm

Materials: - sliding closings in 1 mm powder-coated steel sheet,
with 2 Ø25 mm holes at each side for moving the closing.
Nickel-plated lock.

- Master key

- slides in 1 mm powder-coated steel sheet, interior in
high-tech polymer

Colours: - metal grey or matt white closings

- metal grey or matt white slides

Assembly: fasten onto the vertical rods of the uprights with screws.
Closings fit into the slides

Notes: see table 2 for the compatibility with the shelves

2660-XXXX

See table 2

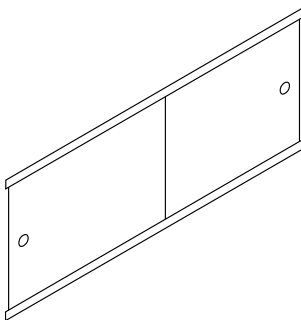
**XXXX=colour option:**

GMGM = Metal Grey closings, Metal Grey slides
GMBO = Metal Grey closings, Matt White slides
BOGM = Matt White closings, Metal Grey slides
BOBO = Matt White closings, Matt White slides
RGM = Red closings (RAL 3002), Metal Grey slides
RBO = Red closings (RAL 3002), Matt White slides

Steel sheet sliding closings:

Dimensions: L96 x H36 cm

Materials: - sliding closings in 1 mm powder-coated steel sheet,
with 2 Ø25 mm holes at each side for moving the closing
- slides in 1 mm powder-coated steel sheet, interior in
high-tech polymer

Colours: - metal grey, matt white, red, yellow, orange or turquoise
closings

- metal grey or matt white slides

Assembly: fasten onto the vertical rods of the uprights with screws.
Closings fit into the slides

Notes: see table 2 for the compatibility with the shelves

XXXX=colour option:

GLGM = Yellow closings (RAL 1032), Metal Grey slides
GLBO = Yellow closings (RAL 1032), Matt White slides
ARGM = Orange closings (RAL 2008), Metal Grey slides
ARBO = Orange closings (RAL 2008), Matt White slides
TUGM = Turquoise closings (RAL 5018), Metal Grey slides
TUBO = Turquoise closings (RAL 5018), Matt White slides

2660-LXX

See table 2

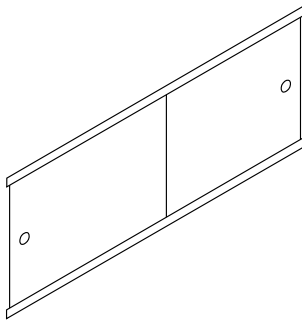
**XXXX=colour option:**

LGM = Oak veneered / Walnut veneered closings, Metal Grey slides

LBO = Oak veneered / Walnut veneered closings, Matt White slides

Sliding closings in wood finish:**Dimensions:** L96 x H36 cm

Materials: - sliding closings in aluminum plated MDF that are wood veneered, with 2 Ø25 mm holes at each side for moving the closing

- slides in 1 mm powder-coated steel sheet, interior in high-tech polymer

Colours: - closings in oak veneered on one side and walnut veneered on other side

- metal grey or matt white slides

Assembly: fasten onto the vertical rods of the uprights with screws.

Closings fit into the slides

Notes: see table 2 for the compatibility with the shelves

2663-TXX

See table 2

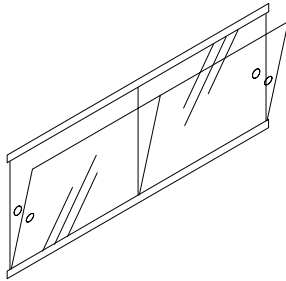
**XX=colour option:**

GM = Metal Grey

BO = Matt White

Sliding flap closings in transparent methacrylate:**Dimensions:** L96 xH36 cm

Materials: - sliding closings in 2 mm transparent, methacrylate, with 2 Ø25 mm holes at each side for moving the closing

- slides in 1 mm powder-coated steel sheet, interior in high-tech polymer

Colours: - transparent closings

- metal grey or matt white slides

Assembly: fasten onto the vertical rods of the uprights with screws.

Closings fit into the slides

Notes: - closings which can double as displays for photographs, art work

- see table 2 for the compatibility with the shelves

2687-XX

See table 2

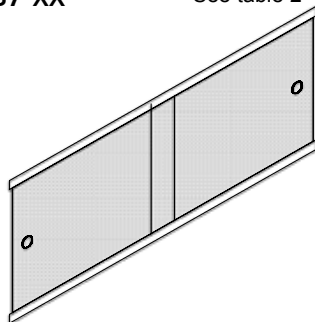
**XX=colour option:**

GM = Metal Grey

BO = Matt White

Screen-printed transparent glass sliding closings:**Dimensions:** L96 x H36 cm

Materials: - sliding closings in tempered 5 mm screen-printed float glass, with 2 Ø25 mm holes at each side for moving the closing

- slides in 1 mm powder-coated steel sheet, interior in high-tech polymer

Colours: - transparent closings screen-printed in white

- metal grey or matt white slides

Assembly: fasten onto the vertical rods of the uprights with screws.

Closings fit into the slides

Notes: - see table 2 for the compatibility with the shelves

- Design Frida Doveil



2675-XX

See table 2

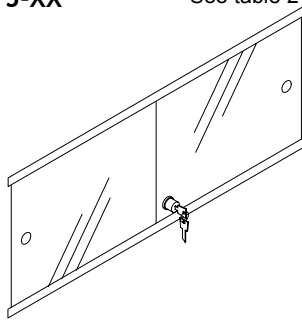
**XX=colour option:**

GM = Metal Grey

BO = Matt White

Transparent glass sliding closings with lock:**Dimensions:** L96 x H36 cm**Materials:** - sliding closings in tempered 5 mm float glass, with 2 Ø25 mm holes at each side for moving the closing. Nickel-plated metal lock.

Master key

- slides in 1 mm powder-coated steel sheet, interior in high-tech polymer

Colours: - transparent closings

- metal grey or matt white slides

Assembly: fasten onto the vertical rods of the uprights with screws.

Closings fit into the slides

Notes: see table 2 for the compatibility with the shelves**2664-XX****2666-XX**

See table 2

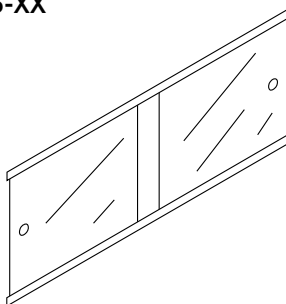
**XX=colour option:**

GM = Metal Grey

BO = Matt White

Transparent glass sliding closings:**Dimensions:** L96 x H36 cm (cod.2664-XX)

L96 x H37 cm (cod.2666-XX)

Materiali: - sliding closings in tempered 5 mm float glass, with 2 Ø25 mm holes at each side for moving the closing

- slides in 1 mm powder-coated steel sheet, interior in high-tech polymer

Colours: - transparent closings

- metal grey or matt white slides

Assembly: fasten onto the vertical rods of the uprights with screws.

Closings fit into the slides

Notes: art. 2666 closings are only mounted if the upper surface is in glass**Notes:** see table 2 for the compatibility with the shelves**2667-XX****2672-XX**

See table 2

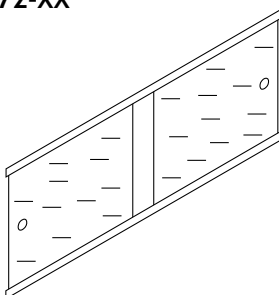
**XX=colour option:**

GM = Metal Grey

BO = Matt White

Acid-treated glass sliding closings:**Dimensions:** L96 x H36 cm (cod.2667-XX)

L96 x H37 cm (cod.2672-XX)

Materials: - sliding closings in acid treated tempered 5 mm float glass, with 2 Ø25 mm holes at each side for moving the closing

- slides in 1 mm powder-coated steel sheet, interior in high-tech polymer

Colours: - Acid-treated closings

- metal grey or matt white slides

Assembly: fasten onto the vertical rods of the uprights with screws.

Closings fit into the slides

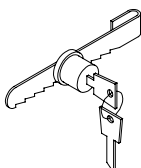
Notes: art. 2672 closings are only mounted if the upper surface is in glass**Notes:** see table 2 for the compatibility with the shelves**2659****Locks for glass closings:****Materials:** steel**Colours:** chrome-plated**Assembly:** fastens to sliding glass closings**Notes:** 2 keys provided standard

To use only with transparent sliding glass closings (art. 2664/2666)

TABLE 2

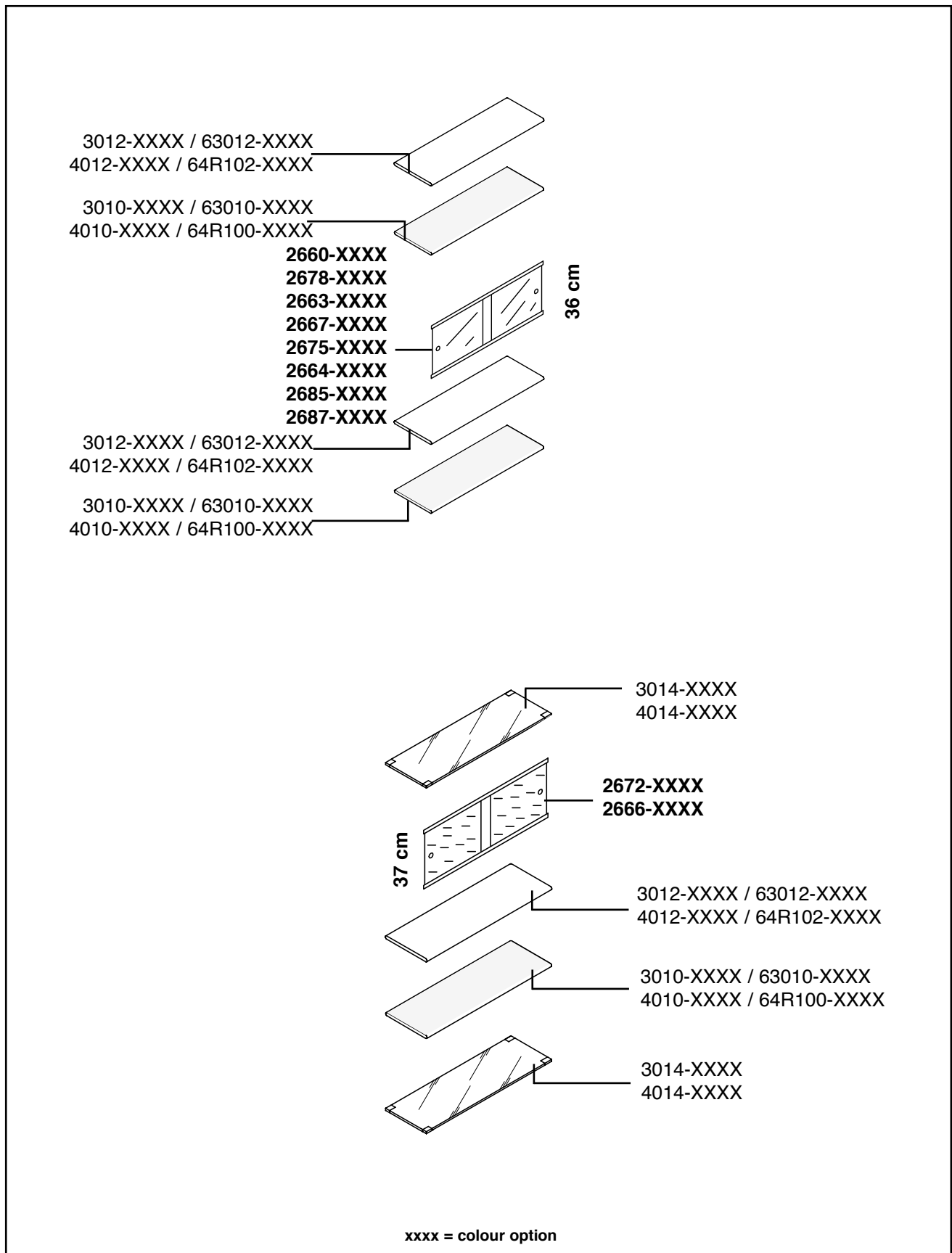

2679

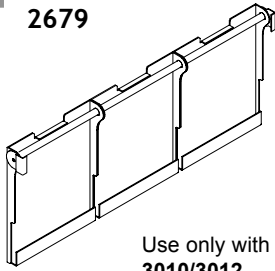

Use only with shelves:
3010/3012
4010/4012
63010/63012
64R100/64R102

Three-panels display, in methacrylate:**Dimensions:** L96 x H43,5 cm

Materials: - satin finish methacrylate displays, 3 mm thick, front
 containment edge D22 x H45 mm
 - chrome-plated tubular steel, Ø20 mm
 - 2 mm metal grey powder-coated steel side supports

Colours: translucent

Assembly: fasten onto the vertical rods of the upright with M4 screws

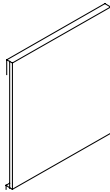
2612-XX
2625-XX

XX=colour option:
 GM = Metal Grey
 BO = Matt White

Exterior closings in steel sheet:**Dimensions:** SOCRATE 35 L33 x H38 cm (cod.2625-XX)

SOCRATE 45 L43 x H38 cm (cod.2612-XX)

Materials: 1 mm powder-coated steel sheet, folded edges**Colours:** metal grey or matt white**Assembly:** fastened directly to the horizontal rods of the uprights**Notes:** article numbers refer to the pair

Use only on end uprights (outer)

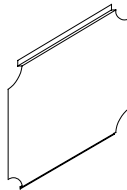
2735-XX
2738-XX

XX=colour option:
 GM = Metal Grey
 BO = Matt White

Inside closings in steel sheet:**Dimensions:** SOCRATE 35 L33 x H38 cm (cod.2738-XX)

SOCRATE 45 L43 x H38 cm (cod.2735-XX)

Materials: 1 mm powder-coated steel sheet, folded edges**Colours:** metal grey or matt white**Assembly:** fastens directly onto the horizontal rods of the uprights**Notes:** article numbers refer to the pair

Use only on end uprights (outer)

4110-XX

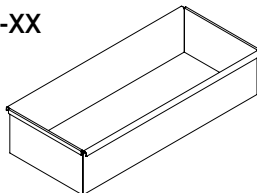

XX=colour option:
 GM = Metal Grey
 BO = Matt White

Steel container unit:**Dimensions:** SOCRATE 45 L100x D43 cm**Materials:** powder-coated steel**Colours:** metal grey or matt white**Assembly:** directly onto the uprights**Notes:** available only for the depth of 45 cm

6A63

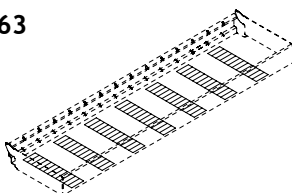
**Adhesive antislip strips:****Dimensions:** L5 x D38 cm**Materials:** black antislip high-tech polymer with an adhesive tape**Colours:** black**Notes:** Use with container unit cod. 4110**Notes:** available only for the depth of 45 cm

4993-N
4993-T



Cable holder:

Materials: high-tech polymer
Colours: black or transparent
Assembly: directly to the vertical rods of the uprights
Notes: 8-piece kit

2757-XX

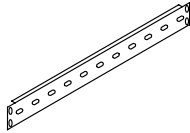

XX=colour option:
GM = Metal Grey
BO = Matt White

Universal support hardware:

Dimensions: L96 x H6 cm (cod.2757-XX)
Materials: 3 mm powder-coated steel sheet, with a holes at either end
Colours: metal grey or matt white
Assembly: fastens onto the vertical rods of the uprights with M4 screws, wing nuts and washers
Notes: with 20x9 mm slots for fastening the blister holder (art. 2765), hanger support (art. 2770) and chrome plated tubular steel supports (art. 2763)

2765



Use only with support:
2757

Blister holder in chrome-plated steel:

Dimensions: D20 x L2,8 cm
Materials: steel rod Ø5 mm with slotted hardware plate to fasten onto the universal supports
Colours: chrome-plated
Assembly: fastens onto slotted hardware plate at each end, M4 screws, wing nut and washers

2763

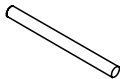

Use only with support:
2757

Chrome-plated metal support:

Dimensions: L30 x Ø2 cm
Materials: chrome-plated steel tube with a threaded M8 bushing
Assembly: fastens with M8 screws

2770-XX

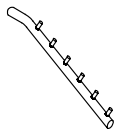

Use only with support:
2757

XX=colour option:
GM = Metal Grey
BO = Matt White

Hanger holder coated steel:

Dimensions: L36 cm
Materials: Ø25 mm powder-coated steel sheet, fitted with pegs Ø6 x H30 mm, located 40 mm apart for fastening hangers
Colours: metal grey or matt white
Assembly: fastens with M8 screws

2812-XX
2862-XX

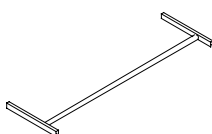

XX=colour option:
GM = Metal Grey
BO = Matt White

Clothes rack/foot rest:

Dimensions: SOCRATE 35 L96 x D33,5 cm (cod.2812-XX)
 SOCRATE 45 L96 x D43,5 cm (cod.2862-XX)
Materials: - chrome-plated Ø20 mm tubular steel
 - side brackets in 1 mm powder-coated steel sheet in metal grey or matt white
Assembly: fastens directly onto the horizontal rods of the upright with M8 screws

2895-XX

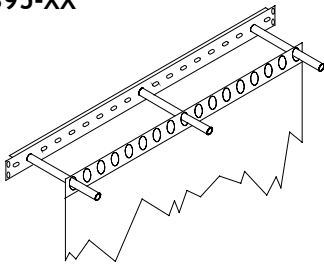

XX=colour option:
GM = Metal Grey
BO = Matt White

Technical drawing holder:

Dimensions: L96 x D30 cm

Materials: - universal support in powder-coated steel sheet, 3 mm thick, with a hole at each end
- L30 x Ø2 cm chrome-plated steel tubes, fitted with a threaded M8 bushing at the end

Colours: metal grey or matt white

Assembly: - bracket fastens onto the vertical rods of the upright M4 screws, wing nuts and washers
- Fasten of the tubes to the slots of the support by M8 screws

Notes: adjustable space

2746-XX

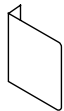

XX=colour option:
GM = Metal Grey
BO = Matt White

Sign banner:

Dimensions: L12 x H12 cm

Materials: folded 1 mm powder-coated steel sheet

Colours: metal grey or matt white

Assembly: fasten onto the vertical rods of the uprights with M4 screws, wing nuts and washers

6A52



Use only with shelves:
3010/3060/3012/3062/3910/3960
4010/4060/4012/4062/4910/4960
63010/63060/63012/63062
64R100/64R600/64R102/64R602

Shelf marker:

Dimensions: L12 x H2,3 cm

Materials: transparent polymer

Assembly: directly to the edge of the steel shelf with a double sided tape

Notes: code refers to 10 pieces

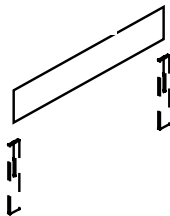
6A2272
6A2274**Sign bands:**

Dimensions: L96 x H10 cm (cod.6A2272)
L56 x H10 cm (cod.6A2274)

Materials: powder-coated steel sheet with upper and lower sides folded

Colours: metal grey or matt white

Assembly: hooked onto special steel supports (cod. 6A2278)

6A2278

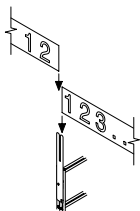
**Support for sign bands:**

Materials: folded powder-coated steel sheet

Colours: metal grey or matt white

Assembly: fasten onto the vertical rods of the uprights with M4 screws, wing nuts and washers

Notes: use only with sign bands cod. 6A2272 e 6A2274

6A2780

**Book holde:**

Dimensions: D24 x H28 cm

Materials: folded chrome-plated steel rods, with a high-tech polymer element to allow them to slide along the track inserted below the metal shelves.

Colours: chrome-plated

Assembly: hooked into the track inserted below the metal shelves
cod. 63010, 63060, 63012, 63062, 64R100, 64R600, 64R102, 64R602

2995/46-XX

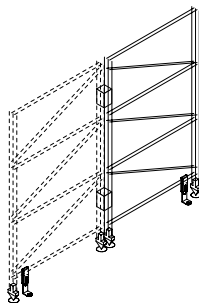

XX=colour option:

GM = Metal Grey

BO = Matt White

Pair of joints for double sided connection:

Materials: transparent high-tech polymer joints and powder-coated steel floor brackets

Colours: transparent joints and metal grey or matt white floor brackets

Assembly:

- joints assembled between the vertical rods of the uprights with screws, wing nuts and washers
- Floor brackets racket fastens directly to the horizontal lower rod of the upright. Adjustable bracket with screws, nuts and washers.

Fastens to the floor with screws, not provided

Notes: for uprights of max height of 238 cm

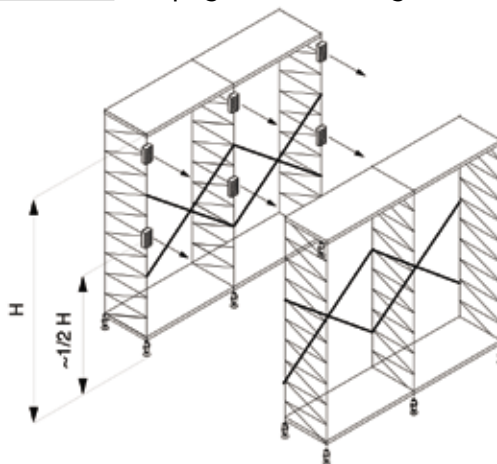

2646-XX

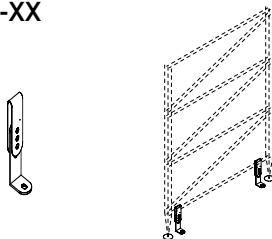

XX=colour option:

GM = Metal Grey

BO = Matt White

Pair of floor brackets:

Materials: Powder-coated steel floor brackets

Colours: Metal Grey or Matt White

Assembly: bracket fastens directly to the horizontal lower rod of the upright. Adjustable bracket with screws, nuts and washers. Fastens to the floor with screws, not provided

Notes: To be uses only for shelving systems not attached to the wall

2996-GM

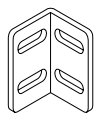

Pair of corner brackets:

Materials: 2 mm powder-coated steel

Colours: metal grey

Assembly: fasten onto the vertical rods of the upright with M4 screws, wing nuts and washers

Notes: code refers to the pair
Used for the connection of uprights with fixed 90° angles

4994-XX

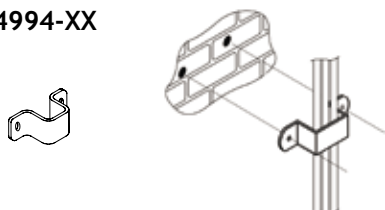

XX=colour option:

GM = Metal Grey

BO = Matt White

Wall mounting:

Materials: powder-coated bent steel

Colours: mat white or metal grey

Notes: fastens to the wall with screws, not provided



ST.051/4ENG

CAIMI BREVETTI S.p.A. - Via Brodolini, 25/27 - 20834 Nova Milanese - MB - Italy - tel. 0362 49101
Ufficio Vendite Italia: tel. 0362 491001 - fax 0362 491060 - e-mail: vendite.italia@caimi.com
Export Department: tel. (+39) 0362 491002 - fax (+39) 0362 491061 - e-mail: export.dept@caimi.com
www.caimi.com

Caimi Brevetti S.p.A. reserves, by its unappealable judgment, the right to modify without prior notice the building materials, the technical and aesthetic specifications, as well as the dimensions of the products in this technical sheet, where pictures and colours are purely as an indication.
